

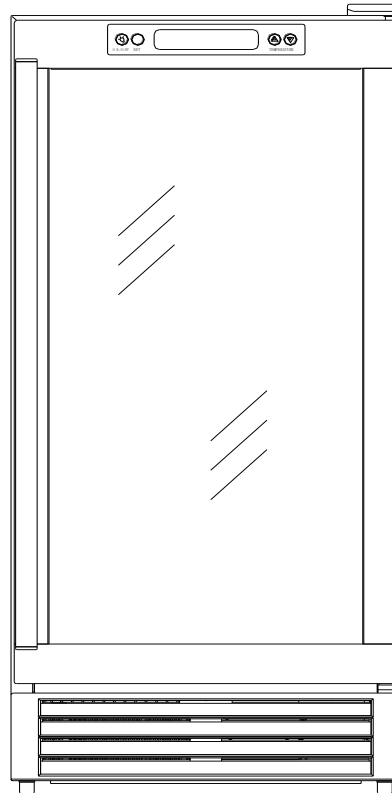

The ultimate outdoor grilling experience.

Phone: 1 (888) 287-3333 ♦ Fax: 1 (877) 855-5373 ♦ #106-2480 Mt. Lehman Road, Abbotsford, BC V4X 2N3

OWNER'S MANUAL: Outdoor Beverage Center



Be sure unit is standing upright 24 hours prior to plug-in.

Model: SC900D

!Important Notice!

Please read ALL safety notices on PP. 1-2 before assembling or operating this appliance

IMPORTANT SAFEGUARDS

Read all instructions before using this appliance. Use this appliance only for its intended purpose as described in this instruction manual. Always exercise basic safety precautions, as described below. After reading the instruction manual, store it in an accessible place where the user(s) of this product can easily find it.

The purpose of these safety precautions is to ensure safe and correct use of the product to minimize risks that could cause serious damage and injury to you or others. The safety precautions are divided into WARNINGS and CAUTIONS. Cases where improper handling of the unit could lead to death or serious injury are listed under the WARNING heading. However, the cases listed under CAUTION could also lead to serious results. To ensure safety, adhere strictly to both types of safety precautions.

WARNING

1. All repairs, disassembly and modifications should be performed only by qualified technicians. Attempting to perform these yourself could result in fire, malfunction and injury.
2. Never splash water directly onto the product or wash with water without unplugging as a short circuit could result. In a rainy environment, a water-proof covering is recommended.
3. Never put flammable or volatile substances into unit as explosion and fire could result.
4. Do not damage, modify, excessively bend, strain, twist or bundle the power cord. Also, placing heavy objects on the power cord or binding could damage the cord, possibly resulting in electrical shock or fire.
5. Use a dedicated wall outlet. Do not use an extension cord or multiple-outlet adaptor as this could result in electrical shock, overheating and fire.
6. Never use flammable spray cans or leave flammable substances near the unit. Sparks from electrical switches could result in explosion or fire. If a combustible gas is present near the appliance, turn off the source of the gas, then open the windows and doors to allow the gas to dissipate. To avoid an explosion, do not pull the plug or switch off the unit.
7. The electrical socket must have good grounding. The ground wire cannot be connected with a gas pipe, heating pipe, water pipe, telephone line or lightning rod. It cannot be replaced with the neutral wire of single-phase power. In addition to the ground wire, an electrical leakage circuit breaker is also required.
8. If installation in a damp location is unavoidable, have an electrician install a ground fault circuit interrupter (GFCI) electrical outlet. If no GFCI is installed, electrical shock could result.
9. Never climb onto the unit. The unit could tip over or fall and cause material damage or personal injury.
10. Disconnect the power cord plug from the wall outlet before moving the unit and make sure that the power cord is not damaged during transport. A damaged power cord could result in electrical shock and/or fire.
11. Never unplug the unit by pulling on the power cord. Always grip the plug firmly and pull straight out from the outlet. Pulling the cord could cause wire breakage, possibly resulting in overheating and fire.
12. Repair or replace any cord that is frayed. Do not use a cord that shows cracks or abrasions along its length.

CAUTION

1. This unit must be properly installed in accordance with the installation instructions before it is used. See grounding instructions in the *Installation* section.
2. This model can either be built-in or free-standing. Built-in units vent at the bottom front and airflow at the front of this vent must be unimpeded.
3. Install the unit in a location where the floor is sturdy enough to support the load of the unit. If the floor is not sturdy enough or installation is incorrectly performed, the unit could tip over and cause personal injury. If the unit is placed on a stand, the front surface must be 3" or more back from the edge of the stand in order to avoid accidental tipping of the appliance during normal usage.
4. Never place heavy objects or items containing water on top of the unit. Objects could fall and cause injury and spilled water could cause the deterioration of the insulation of electrical components and result in electrical shock.
5. Disconnect the unit if it is behaving abnormally, and do not reconnect until the situation is corrected.
6. Pull out the plug before doing any maintenance on the unit to avoid electric shock.
7. Never pull out plug when hands are wet!
8. This unit is not intended for the storage of medicines or chemical reagents.
9. Keep packing materials away from children.
10. During long absences, remove the unit's contents, unplug the unit, clean it and leave the door open slightly to avoid possible formation of condensation, mold or odors. Use a cover to protect the unit and prolong its lifespan.
11. Leave disassembly and disposal of the unit to qualified experts.

**SAVE THESE INSTRUCTIONS!
DANGER!**

Risk of child entrapment! Before discarding your old refrigerator:

- take off the doors
- leave the shelves in place so that children may not easily climb inside.

Table of Contents

IMPORTANT SAFEGUARDS 1 – 2

Exploded Parts Diagram 3 – 4

Technical Specifications 4

Installation 5

Operating Your Beverage Center 6 – 7

Cleaning and Maintenance 8

Troubleshooting 9

Limited Warranty 10

Special Message 11

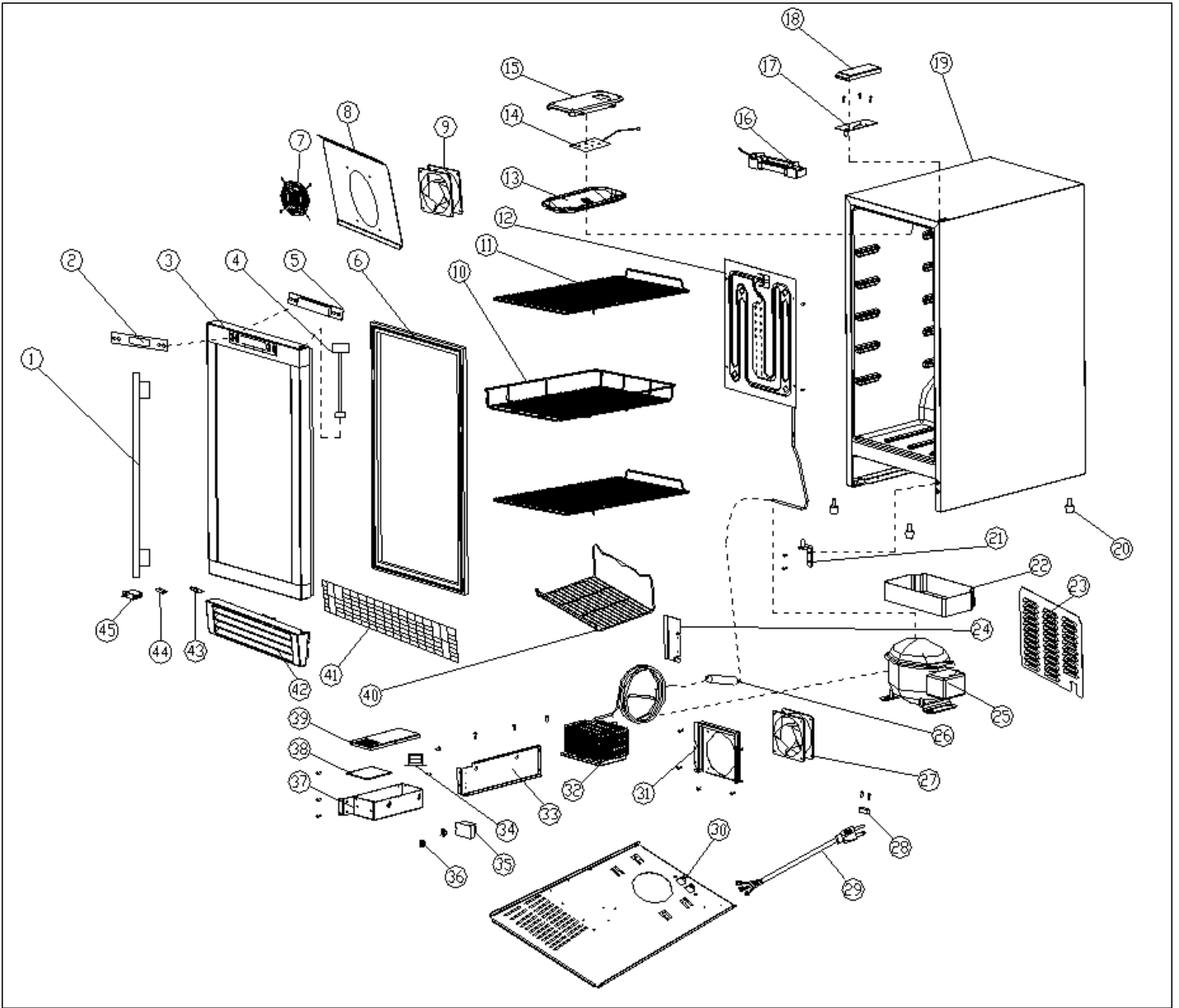

#	Description	Part #	Qty	#	Description	Part #	Qty
1	Handle	JO-1861701700	1	24	Wind Baffle	JO-1849735700	1
2	Panel Overlay	JO-1864806003	1	25	Compressor	JO-1858422000	1
3	Glass Door	JO-1842001005	1	26	Dry Filter	JO-1880007800	1
4	Panel wire	JO-1853109100	1	27	Condenser Fan	JO-1851765700	1
5	Control Panel	JO-1864805803	1	28	Cord Holder	JO-1864201200	1
6	Door Gasket	JO-1864015400	1	29	Power supply cord	JO-1853113802	1
7	Fan housing	JO-1861751200	1	30	Soleplate	JO-1860020700	1
8	Fan Fixing Plate	JO-1860008801	1	31	Fan Fixing Plate	JO-1860550302	1
9	Evaporator fan	JO-1851765700	1	32	Condenser	JO-1880039700	1
10	Flat basket	JO-1800501002	1	33	Air Passage Plate	JO-1860550405	1
11	Shelves	JO-1800500900	2	34	Transformer	JO-1854810001	1
12	Evaporator	JO-1880026201	1	36	Protective Ring	JO-639704600	2
13	LED Light Cover	JO-1849735400	1	37	Controller box	JO-1860020800	1
14	LED Light (blue)	JO-1853109000	1	38	Controller Board	JO-1854206502	1
15	Light Holder	JO-1849735501	1	39	Controller box cover	JO-1860020900	1
17	Top Hinge	JO-1860414801	1	40	Small Basket	JO-1800500800	1
18	Hinge Cover	JO-1864400201	1	41	Rodent-Resistant Mesh	JO-1861751100	1
19	Cabinet	JO-1871046301	1	42	Louver	JO-1845744400	1
20	Feet	JO-1864620000	4	43	Magnet Catch	JO-186000900L	1
21	Bottom Hinge	JO-1860416302	1	44	Switch Contactor	JO-1860008602	1
22	Water Disposal Pan	JO-1864802300	1	45	Light Switch	JO-1854006300	1
23	Back Shroud	JO-1860008505	1				

Technical Specifications

Model Number: SC900D

Description: Outdoor Beverage Center

Electrical Input: 115VAC ~ 60Hz

Current Rating: 2.0A

Unit Dimensions: 14⁵/₈"W x 24³/₈"D x 33¹/₂"H

Unit Weight: 76 lbs

Ambient Temperature Range: -4°C - 38°C (25°F - 100°F)

Compartment Temperature Range: 2°C – 18°C (36°F - 64°F)

Control Panel

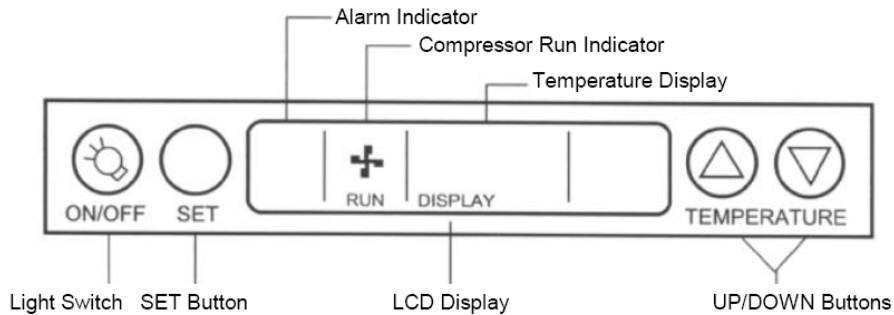

Please note: You can switch temperature display setting from degrees Fahrenheit to degrees Celsius by pressing and holding the UP button for 10 seconds. The temperature in degrees Fahrenheit or degrees Celsius will appear in the temperature display window.

Installation

Remove the exterior and interior packaging. Use a soft dry cloth to wipe down the outside of the Beverage Center thoroughly. Use a clean cloth dampened with lukewarm water to wipe down the interior.

Air must circulate freely in front of the Beverage Center. Avoid placing it near any source of heat or moisture, or in direct sunlight. Direct sunlight may affect the finish, and nearby heat sources will cause higher electrical consumption.

The SC900D Outdoor Beverage Center is designed to be either free-standing or built-in. It has motorized fans at the back of the unit that direct compressor-generated heat away from the compressor and through the front of the unit. Keep the front vents unobstructed. If the unit is built-in, allow minimum clearances of 1/4" at the sides, 1/2" at the back and 1" at the top.

Electrical Connection

Important! For your personal safety, this appliance must be properly grounded. In the event of an electrical short circuit, grounding reduces the risk of shock by providing an escape wire for the electric current. This appliance is equipped with a cord having a grounding wire with a grounding plug. The plug must be inserted into an outlet that is properly grounded and installed. The ground wire cannot be connected to a gas pipe, heating pipe, water pipe, telephone line or lightning rod. It cannot be replaced with the neutral wire of single-phase power. In addition to the ground wire, an electrical leakage circuit breaker is also required. Consult a qualified electrician if you do not completely understand these grounding instructions.

DO NOT UNDER ANY CIRCUMSTANCES CUT OR REMOVE THE THIRD (GROUND) PRONG FROM THE POWER CORD.

If installation in a damp location is unavoidable, have an electrician install a ground fault circuit interrupter (GFCI) electrical outlet. If no GFCI is installed, electrical shock could result.

Do Not Use an Extension Cord

Avoid the use of an extension cord because of potential safety hazards under certain conditions.

Operating Your Beverage Center

IMPORTANT: Do not plug in the Beverage Center for 24 hours after unit is set in place. Failure to do so may result in the unit working improperly.

Compartment Design

The SC90OD Beverage Center has a capacity of 28 standard wine bottles or 84 cans. The unit has 3 adjustable chrome-plated flat wire shelves and a wire basket to hold cans and bottles of beverages such as beer, water and soft drinks. This design enables you to operate the unit as a Beverage Center or wine cellar. The control panel also allows you to set a different temperature for Beverage Center or wine cellar. The control panel displays the current temperature inside the compartment and allows you to turn the interior light on and off.

OPERATING INSTRUCTIONS

Turning On the Unit

The Beverage Center turns on automatically when it is plugged in. The unit employs a heater inside the cabinet and is designed for outdoor use. When the air temperature is below **4°C (40°F)**, the compressor will stop working and the heater will work automatically to maintain the temperature setting. If the Ambient temperature is below **-4°C (25°F)**, do not use the unit to storage anything.

If you want to use the Automatic Temperature (default) setting, do nothing further. The SC90OD will automatically set the temperature at **5°C (41°F)**. If you want to set other temperatures, see below.

Temperature Setting

*While wines store best at temperatures around **13-15°C (56-58°F)**, the SC90OD outdoor unit also allows you to store wine at drinking temperatures. Generally, RED WINE should be kept at **15-16°C (60-61°F)** and WHITE WINE, which is usually served chilled, is best kept at **12-13°C (54-55°F)**. Sparkling wines should be kept at about **8°C (46°F)**. For beer and soft drinks, choose the temperature setting that is most agreeable to you and your guests.*

To adjust the temperature, press the SET button, then use the UP/DOWN keys to navigate to the preferred temperature. The range of set temperatures is from **2 to 18°C (36 to 64°F)**. For example, if you are storing red wine, you may want to set a temperature of **16°C (61°F)**. When the correct temperature appears in the DISPLAY window of the control panel, press SET to confirm. The actual temperature inside the unit will now appear in the window. This temperature will vary depending on the number of bottles stored and how frequently the door is opened.

Please note: The temperature sensor records the average temperature of the unit. Cold air falls and warmer air rises, and there will be a temperature variation from the bottom to the top of the unit. The temperature at the bottom of the unit will always be slightly colder. The controller only controls the average temperature of the unit. The temperature displayed by the electronic control panel is the instantaneous average temperature of the unit and there may be a variation of approximately **0 to 3°C (0 to 6°F)**.

When fully loaded with room temperature product, the SC90OD will operate continuously for as long as 24 hours to reduce the temperature inside the cabinet to the desired point. Under normal conditions, when the unit has been on for six hours, it will stop working for about thirty minutes to defrost automatically. The unit should be in a well-ventilated area. Best results are obtained at temperatures between **18°C (65°F)** and **27°C (80°F)** for built-in models and between **18°C (65°F)** and **32°C (90°F)** for freestanding models.

To temporarily stop the cooling cycle, unplug the Beverage Center. To shut it down for longer periods of time, disconnect the plug and leave the door partially open.

NOTE: If you unplug the Beverage Center, allow 3 minutes before plugging it back in. The unit will not restart in less than 3 minutes.

Memorized Temperature Settings

Your unit has been designed to “remember” the last run mode to which it was set. If there is a power outage or any other power cutoff, the unit will automatically return to the previous temperature setting after the power has returned.

Compressor Run Indicator

When the unit’s compressor is running, the control panel will display a moving icon representing a running fan. If the compressor stops running, the icon will stop running as well.

About the Liquid Crystal Display (LCD)

When you press any button on the control panel, a backlight will appear in the display. If no other button is pressed, the backlight will automatically go out after 2 minutes.

ALARM Mode

In the event that there is a fault in the unit, an ALARM indication will appear on the screen.

In ALARM mode, the unit will make a beeping sound and display an alarm message. If the LCD on the control panel displays any of the following messages: PROBE ERROR, LOW TEMP or HIGH TEMP, consult the *Troubleshooting* section of this manual.

Interior Light

The interior light can be operated manually by pressing the ON/OFF button on the control panel. The light will automatically turn off after 5 minutes.

NOTE: Avoid overuse of the interior light since the heat generated can raise the temperature of the stored contents.

Shelving

The wire racks in your unit are chrome-plated so they will not rust. The unit has 3 adjustable chrome-plated flat wire shelves and a wire basket to hold cans and bottles of beverages such as beer, water and soft drinks.

The racks are removable and reversible. To remove a rack, take out the bottles on the rack and pull it out until it stops. Then lift up the front of the rack and remove it from the unit.

Cleaning and Maintenance

Cleaning the Outside

Unplug your Beverage Center. Clean the outside with a cloth dampened in mild soapy water. Dry thoroughly with a soft cloth. To clean the door gasket, use only mild soapy water. Never use harsh cleansers or scouring pads to clean any part of your unit.

Cleaning the Inside

Unplug your Beverage Center and remove its contents. Rinse the inside surfaces with plain water and dry the chrome racks, basket and shelving. Avoid getting excess water inside the machine since it will flow into the water trap near the compressor and possibly overflow.

Defrosting the Unit

The unit uses an automatic defrost system in which the refrigerated surfaces of the unit defrost automatically. Defrost water drains into a hole in the floor of the storage compartment and is channeled into a drain pan located at the back of the unit near the compressor. Heat transferred from the compressor evaporates any water that has collected in the pan. Be sure the drain hole in the floor of the unit is clear and unobstructed.

Troubleshooting

Unit does not turn on

Not plugged in.

Fuse blown or circuit breaker tripped.

Noise or vibration

Check that unit is level. If not, adjust leveling legs.

Unit is too warm

Check that door is properly closed and sealed.

Check temperature setting. (To change the temperature setting, follow the steps in the *Operating Your Beverage Center* section of this manual.)

Check if door has been opened frequently.

LCD displays “PROBE ERROR”

This message is an ALARM MODE indication. The LCD displays “PROBE ERROR” on the left when the thermostatic sensor has malfunctioned. Contact your authorized service facility for sensor replacement.

LCD displays “LOW TEMP”

This message is an ALARM MODE indication. The LCD displays “LOW TEMP” on the left and “L” in the middle. It indicates that the actual temperature is much lower than your set temperature.

LCD displays “HIGH TEMP”

This message is an ALARM MODE indication. The LCD displays “HIGH TEMP” on the left and the actual temperature reading in the middle. It indicates that the actual temperature is much higher than your set temperature. Possible causes are:

- The door might not be fully closed.
- The refrigerant may have leaked.
- The heater may not be functioning properly and should be replaced.

If you are certain that the door is not the cause of the problem, contact your authorized service facility immediately.

Jackson Grills Limited Warranty

Description of Limited Warranty

This limited warranty is given by Jackson Grills to the original purchaser of the refrigeration equipment supplied by Jackson Grills as long as the equipment remains in the possession of the original purchaser.

Your Jackson Grills refrigeration equipment is warranted against defects in workmanship or material for a period of two years from the date of purchase under the following requirements:

1. Registration card must be completed and mailed back to Jackson Grills within 30 days from purchase area.
2. Proof of purchase must be submitted for warranty consideration.
3. Defects must be proven to the satisfaction of Jackson Grills to have been caused by defects in workmanship or material. Jackson Grills may request that defective parts be returned for inspection at the owner's expense.
4. The owner is responsible for the following:
 - a) All freight charges
 - b) Damage sustained in transit
 - c) Mileage charges for service calls
 - d) Proper installation
 - e) Alterations to original equipment
 - f) Removal or installation
 - g) All labour costs
5. During the Limited Warranty parts for the repairs will be provided by Jackson Grills.

In-warranty repair must be performed by factory authorized service centers. For authority to proceed with repairs contact:

Jackson Grills

Warranty Department

106-2480 Mt. Lehman Road

Abbotsford, British Columbia Canada V4X 2N3

Tel: 1-888-287-3333

Special Message to Our Customers:

All of us at Jackson thank you, for choosing a Jackson Grills' product! This appliance was designed, engineered, and built with quality components and we are confident that it will provide you with years of excellent operation.

Please take the time to read the entire manual and familiarize yourself with all of the features of the product. This manual also contains important safety information and operation instructions. Please write your products' serial number in the space below, and ensure that this manual remains handy for quick reference.

To obtain replacement parts for your product, contact your local dealer. If you have any questions please call us anytime at the number below: (Please have your model and serial number at hand)

Model: AZ-20A or BC-900D or SC-900D

Serial Number: _____

Write your serial number here for future reference.

OWNER REGISTRATION: Please take the time to fill out and return a Warranty Registration Card, or on-line at www.jacksongrills.com or simply fill in the form below and mail or fax to:

Jackson Grills
#106-2480 Mt. Lehman Rd.
Abbotsford, BC.
Canada V4X 2N3

Customer Support (Tel):
Customer Support (E-mail):
Fax:
Pars Ordering:

1(888) 287-3333 or
info@jacksongrills.com
1(877)855-5373
Contact your Dealer

.....
Please complete and return within 30 days. Thank you.

Title: Mr. Mrs. Ms. Miss (Circle one)

First Name: _____ Initial: _____ Last Name: _____

Street: _____ Apt.# _____

City: _____ State/ Prov: _____ Zip/ Postal: _____

Phone: _____ Email: _____

Date Purchased: _____ Dealer: _____

Model: _____ Serial #: _____

Comments: _____

Thank you for taking the time to fill out this Ownership and Registration Card

Dear Owner: please keep this manual for future reference.